

Mobile platform for motor assembly access « core engine »

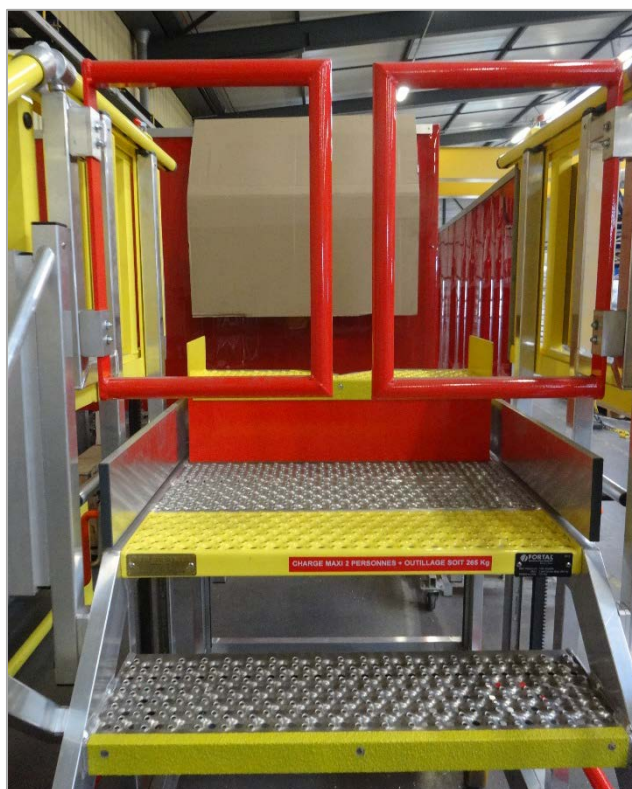

Mobile platform in raw extruded aluminum:

- First step and platform anti-skid grating yellow lacquered
- Raw aluminum handrail
- Side guardrail of the platform and on the handrails (yellow lacquered)
- 2 half-gate red lacquered
- Arche on guardrails orange lacquered for better moving
- At the bottom red lacquered protection arches
- 2 wheels with brake pivoting \varnothing 160 mm at the rear

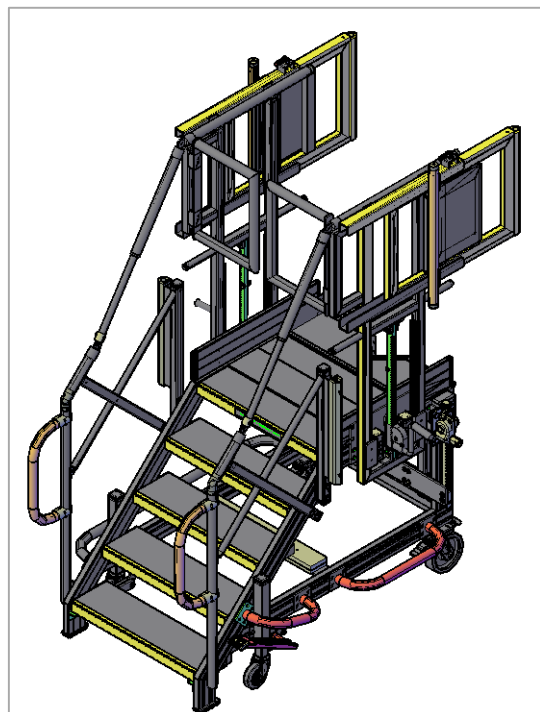

Head office & Plants : ZI du Muckental – F – 67140 BARR
Phone +33(0)3 88 58 53 53 – Fax +33(0)3 88 58 53 54
www.aeronautique.fortal.fr/en – info@ortal.fr

Mobile platform for motor assembly access « core engine »

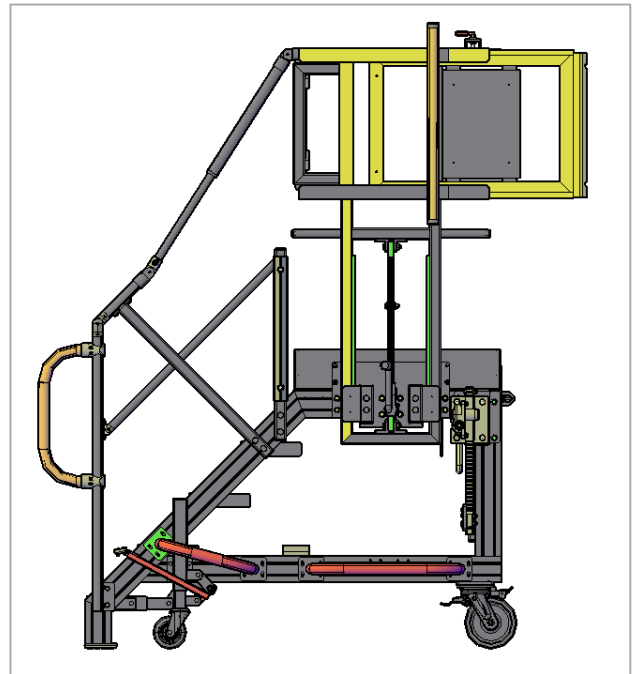

Side guardrail sliding vertically by rack system



Retractable step on the rear side of the platform –
Manually operated.
Shockproof protection.

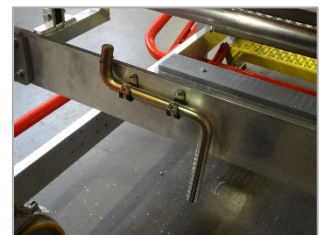

Foot unlocking

Capacity of load: 2 people – 260 kg



Head office & Plants : ZI du Muckental – F – 67140 BARR
Phone +33(0)3 88 58 53 53 – Fax +33(0)3 88 58 53 54
www.aeronautique.fortal.fr/en – info@ortal.fr